

# Protistor DC fuses

## DC Square-body Fuses Sizes 300 - 302 - 2x302 gR Blades size 2x302 - 2000V DC

gRC-gRE from 200 to 560 A

### Dimensions

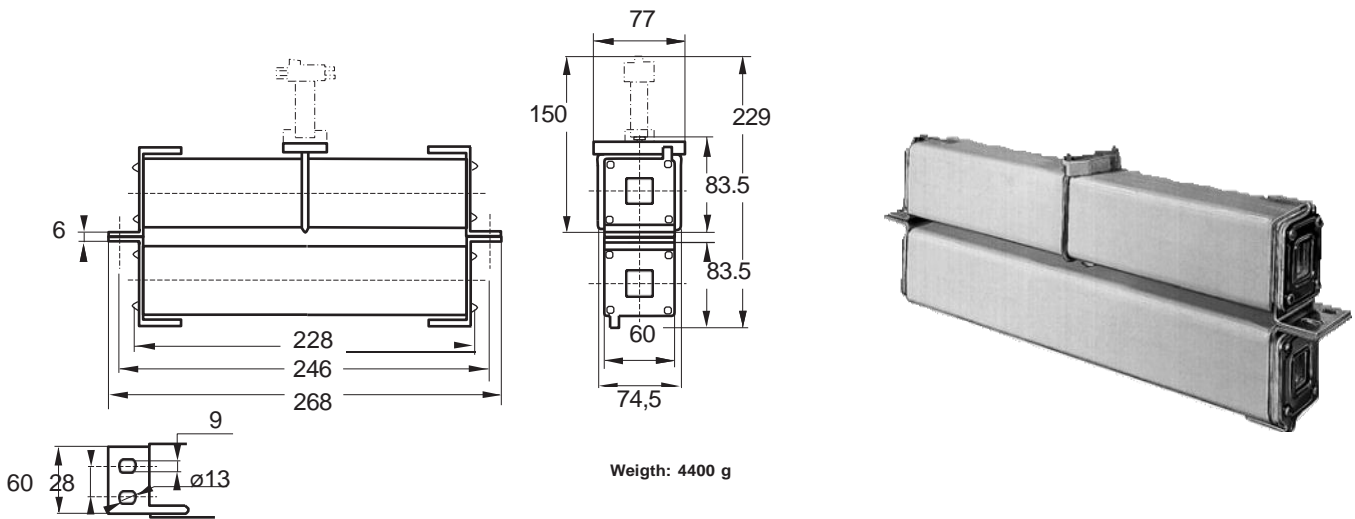

### Main Characteristics

Size	Current rating $I_N$ (A)	Breaking Capacity	Watts loss		Designation	Ref. Number	Catalog Number
			$0.8 I_N$ (W)	$I_N$ (W)			
2x302	200	@ 2000 V DC 30 kA	60	117	CC 20 gRC 2302 QF 200	B079903	D2302GC20C200QF
	250	L/R = 30 ms	74	144	CC 20 gRC 2302 QF 250	C079904	D2302GC20C250QF
	315	@ 2000 V DC 30 kA	84	140	CC 20 gRE 2302 QF 315	X075759	D2302GE20C315QF
	400	L/R = 14 ms	96	160	CC 20 gRE 2302 QF 400	Y075760	D2302GE20C400QF
	500		115	190	CC 20 gRE 2302 QF 500	Z075761	D2302GE20C500QF
	560	@ 1800 V DC 100 kA L/R = 20 ms	120	200	CC 20 gRE 2302 QF 560	A075762	D2302GE20C560QF

Pack: 1 piece

Microswitch MC 2R 3E 1-5N BS Reference number: J310025

# Protistor DC fuses

## DC Square-body Fuses Sizes 300 - 302 - 2x302 gR Blades size 2x302 - 2000V DC



gRC-gRE from 200 to 560 A

### Electrical characteristics

#### DC applications data

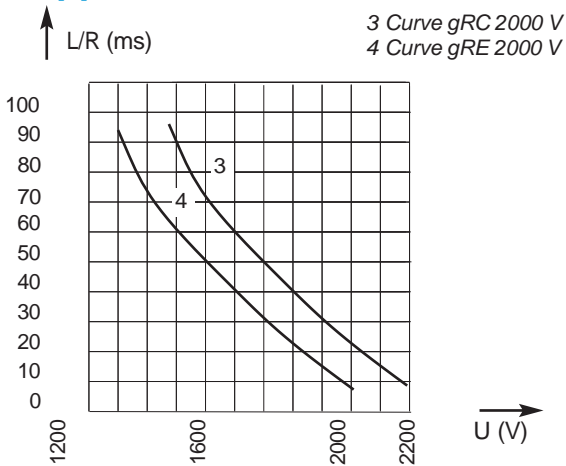

Above: Curves indicate maximum permissible value of time constant L/R as a function of DC working voltage

**Max. AC voltage (50/60 Hz):**  
 1700 V with breaking capacity of 80 kA

#### Time vs. current characteristics

#### Peak arc voltage vs. working voltage

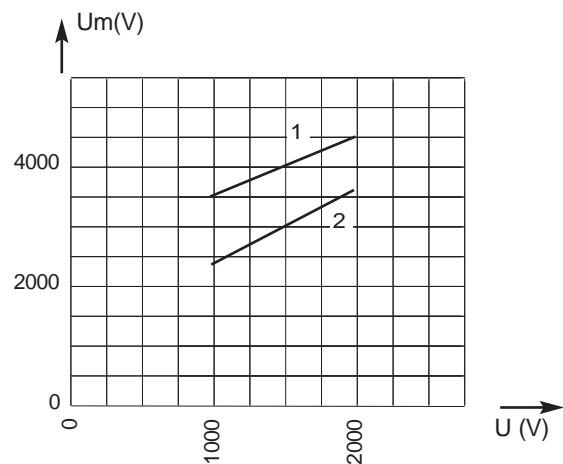

1 Curve gRC : L/R = 30 ms  
 2 Curve gRE : L/R = 15 ms

Above: Curves indicate for various time constants L/R the peak arc voltage which may appear across the fuse terminals, vs. DC working voltage

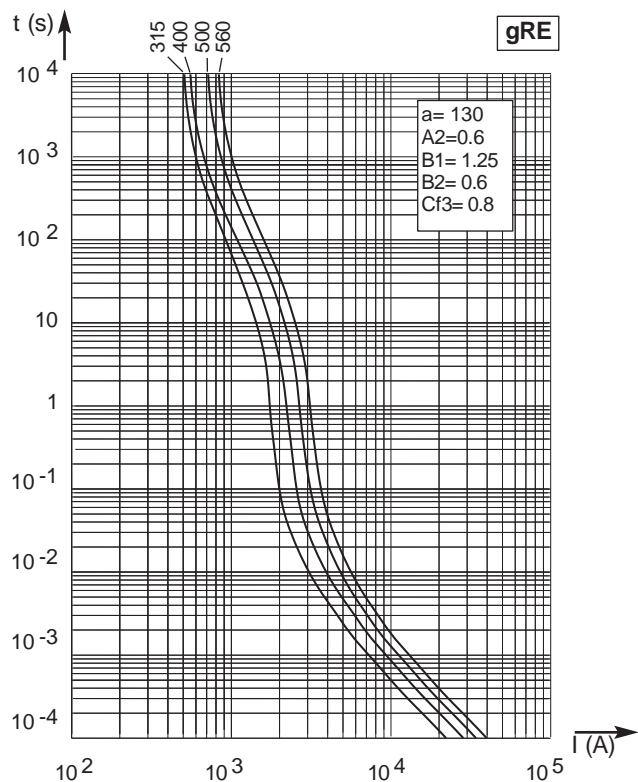
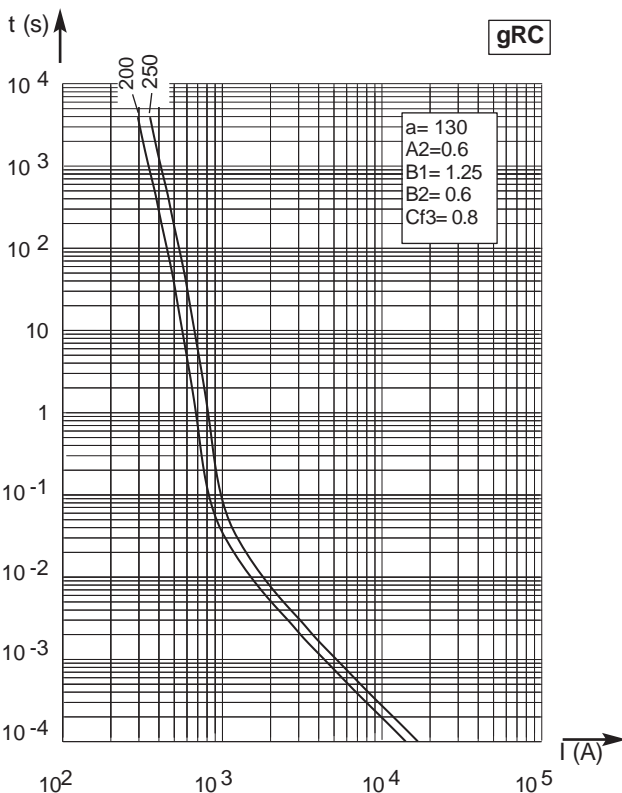

Above, left and right: Curves indicate, for each rated current, pre-arcing time vs. R.M.S. pre-arcing current

±10% tolerance for mean pre-arcing current